

REVISIONS					
REV	ECO	DESCRIPTION	DATE	BY	APPR
A1	--	RELEASE NEW DRAWING	17/OCT/18	BROOK	TOMMY

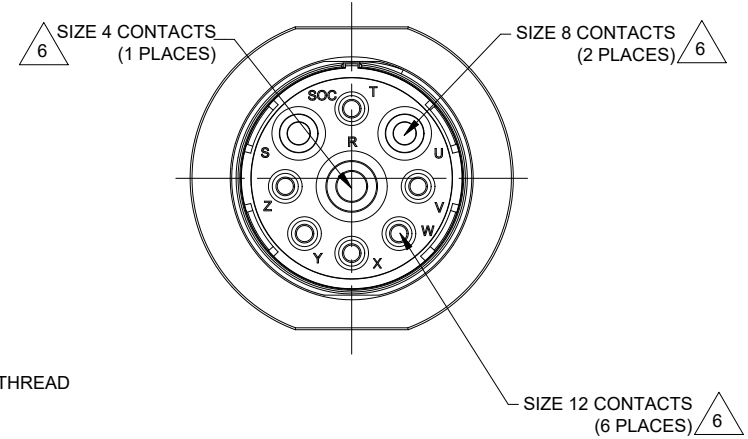

NOTES: UNLESS OTHERWISE SPECIFIED

- MATERIAL:
SHELL: ZINC ALLOY, NICKEL PLATED
INSERT AND RETAINING RING: THERMOPLASTIC
SEAL: SILICONE RUBBER
- MODIFICATIONS: THREADED HOUSING; NORMAL DIA. SEAL
- SPECIFICATIONS:
 - OPERATING TEMPERATURE: -55°C TO +125°C.
 - DIELECTRIC WITHSTANDING VOLTAGE: LESS THAN 2 MILLIAMPS CURRENT LEAKAGE @ 1500 VOLTS AC.
 - INSULATION RESISTANCE: 1000 MEGOHM MIN @ 25°C.
 - MOISTURE RESISTANCE:
IP68 (IM OF WATER FOR A PERIOD OF 24 HOURS, MATED CONDITION);
IP69K (MATED CONDITION)
 - MATING CYCLE DURABILITY: 100 CYCLES
 - RoHS COMPLIANT
- MATING PART: AHDM06-24-09P* (* = SEAL TYPE)
- ALL DIMENSIONS ARE FOR REFERENCE USE ONLY.

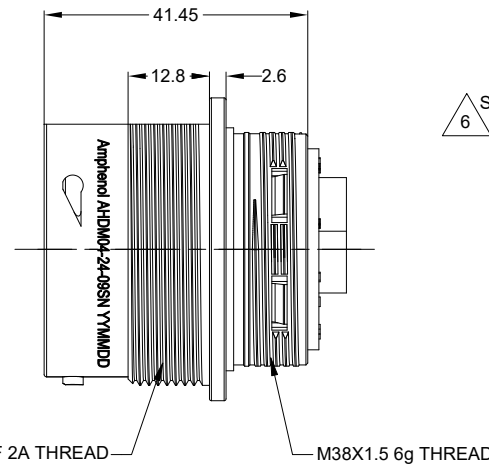
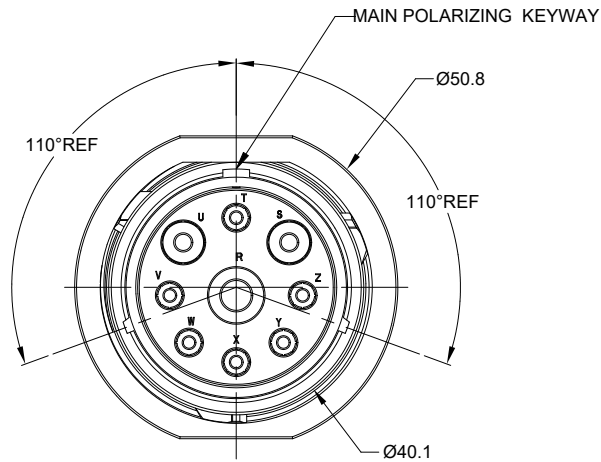
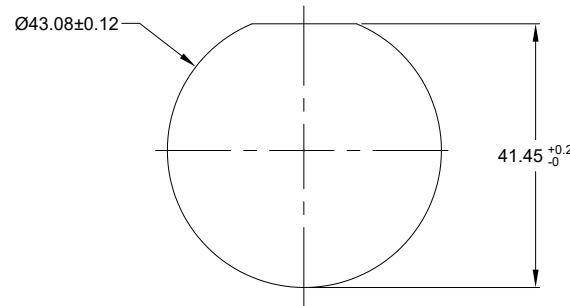

RECOMMENDED PANEL MOUNTING HOLE
RECOMMENDED PANEL THICKNESS: 1.6 TO 4.7MM

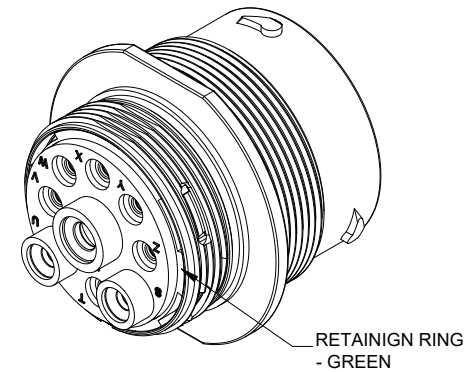

6 CONTACT SIZE AND WIRE RANGE:

CONTACT SIZE	MIN. INSUL O.D.	MAX. INSUL O.D.	TYPICAL WIRE RANGE	CURRENT RATING
4	6.63 mm (.261 in)	7.42 mm (.292 in)	6 AWG (16.0-13.0mm ²)	100 AMPS
8	4.83 mm (.190 in)	6.10 mm (.240 in)	8-10 AWG (10.0-5.0mm ²)	60 AMPS
12	3.43 mm (.135 in)	4.32 mm (.170 in)	10-14 AWG (6.0-2.0mm ²)	25 AMPS

QUANTITY	AHDM04-24-09SN	DESCRIPTION	ITEM												
	REF: HD34-24-9SN														
MATERIALS LIST															
UNLESS OTHERWISE SPECIFIED 1) All dimensions are in metric (mm). 2) Tolerances are as follows: 1 PL DEC ±0.30 2 PL DEC ±0.15 3 PL DEC ±0.08 3) Note reference =		<table border="1"> <thead> <tr> <th>SIGNATURES</th> <th>DATE</th> </tr> </thead> <tbody> <tr> <td>DRAWN: LYNCHPAN</td> <td>17/JAN/24</td> </tr> <tr> <td>CHECKED: SULLENZHANG</td> <td>18/JAN/24</td> </tr> <tr> <td>ENGINEER:</td> <td></td> </tr> <tr> <td>APPROVAL: TOMMY.XIE</td> <td>18/JAN/24</td> </tr> <tr> <td>CUSTOMER:</td> <td></td> </tr> </tbody> </table>		SIGNATURES	DATE	DRAWN: LYNCHPAN	17/JAN/24	CHECKED: SULLENZHANG	18/JAN/24	ENGINEER:		APPROVAL: TOMMY.XIE	18/JAN/24	CUSTOMER:	
SIGNATURES	DATE														
DRAWN: LYNCHPAN	17/JAN/24														
CHECKED: SULLENZHANG	18/JAN/24														
ENGINEER:															
APPROVAL: TOMMY.XIE	18/JAN/24														
CUSTOMER:															
MATERIAL SPECIFICATIONS:		Amphenol													
WEIGHT: 117.28g		Sine Systems - www.amphenol-sine.com 44724 Morley Drive Clinton Township, MI 48036													
PROCESS SPECIFICATIONS:		09POS, RECEPTACLE, SOCKET, SIZE 24, NORMAL SEAL, DURAMATE AHDM													
NEXT ASSY:		THIS DRAWING IS SUPPLIED FOR INFORMATION ONLY. DESIGN FEATURES, SPECIFICATIONS AND PERFORMANCE DATA SHOWN HEREON ARE THE PROPERTY OF THE AMPHENOL CORPORATION. NO RIGHTS OF REPRODUCTION ARE IMPLIED. ALL DIMENSIONS ARE SUBJECT TO NORMAL MANUFACTURING VARIATIONS.													
		SIZE: B C-	DWG NO: AHDM04-24-09SN												
		SCALE: NONE	REVISION: A1												
		SHEET 1 OF 1													

TITLE: 09POS, RECEPTACLE, SOCKET, SIZE 24, NORMAL SEAL, DURAMATE AHDM
DWG NO: AHDM04-24-09SN
REV: A1
SH: 1
OF: 1

ARB, ATHD and DuraMate™ Series

Size 4 Contact & Tooling Options

Contacts - Machined

Part Number	Type	Style	Contact Size	Amp	Wire Range (AWG)	Wire Range (mm ²)	Insulation OD (mm)	Plating	Reel Size	Packaging
AT60-203-04141-4	Pin	Machined	Size 4	100A	4AWG	-	-	Nickel-Plated	-	-
AT60-203-0431-4	Pin	Machined	Size 4	100A	4AWG	-	-	Gold-Plated	-	-
AT60-204-0490	Pin	Machined	Size 4	100A	6AWG	-	-	Nickel-Plated	-	-
AT62-203-04141	Socket	Machined	Size 4	100A	6AWG	-	-	Nickel-Plated	-	-
AT62-203-04141-4	Socket	Machined	Size 4	100A	4AWG	-	-	Nickel-Plated	-	-
AT62-203-0431-4	Socket	Machined	Size 4	100A	4AWG	-	-	Gold-Plated	-	-

Tooling

Part Number	Tool Name	Style	Contact Size	Wire Range (AWG)	Material	Color
96-978-22	Crimper and Die	Machined	Size 3.6mm-10mm	10mm ² -185mm ²	n/a	n/a
AT11-027-0405	Contact Extraction Tool	Machined	Size 4	4AWG	Plastic	Black
WA23	Pneumatic Crimp Tool	Machined	-	8-0000AWG	-	-
WA23-138DA	WA23 Die Assembly for Pneumatic Crimp Tool	Machined	Size 4	4AWG	-	Silver
WA23-11	WA23 Locator for Pneumatic Crimp Tool	Machined	Size 4	4AWG	-	Blue

ARB, ATHD and DuraMate™ Series

Size 8 Contact & Tooling Options

Contacts - Machined

Part Number	Type	Style	Contact Size	Amp	Wire Range (AWG)	Wire Range (mm ²)	Insulation OD (mm)	Plating	Reel Size	Packaging
AT60-204-08141-16	Pin	Machined	Size 8	60A	6AWG	-	-	Nickel-Plated	-	-
AT60-204-08141	Pin	Machined	Size 8	60A	8-10AWG	-	-	Nickel-Plated	-	-
AT62-203-08141-16	Socket	Machined	Size 8	60A	6AWG	-	-	Nickel-Plated	-	-
AT62-203-08141	Socket	Machined	Size 8	60A	8-10AWG	-	-	Nickel-Plated	-	-

Tooling

Part Number	Tool Name	Style	Contact Size	Wire Range (AWG)	Material	Color
96-978-22	Crimper and Die	Machined	Size 3.6mm-10mm	10mm ² -185mm ²	n/a	n/a
AT114008	Contact Extraction Tool	Machined	Size 8	8-10AWG	Plastic	Green
WA23	Pneumatic Crimp Tool	Machined	-	8-0000AWG	-	-
WA23-2	WA23 Die Assembly for Pneumatic Crimp Tool	Machined	Size 8	8AWG	n/a	Silver
WA23-3	WA23 Die Assembly for Pneumatic Crimp Tool	Machined	Size 6	6AWG	n/a	n/a
WA23-10	WA23 Locator for Pneumatic Crimp Tool	Machined	Size 6	6AWG	n/a	Blue

AHD, ARB, ATP, ATHD, DuraMate™ and PanelMate™ Series

Size 12 Contact & Tooling Options

Contacts - Machined

Part Number	Type	Style	Contact Size	Amp	Wire Range (AWG)	Wire Range (mm ²)	Insulation OD (mm)	Plating	Reel Size	Packaging
AT60-204-12141-10	Pin	Machined	Size 12	25A	10-12AWG	-	-	Nickel-Plated	-	-
AT60-204-12141	Pin	Machined	Size 12	25A	12-14AWG	-	-	Nickel-Plated	-	-
AT60-220-1231	Pin	Machined	Size 12	25A	12-14AWG	-	-	Gold-Plated	-	-
AT60-204-12NKIT	Pin	Machined	Size 12	25A	12-14AWG	-	-	Nickel-Plated	-	-
AT60-220-1231-1618	Pin	Machined	Size 12	25A	16-18AWG	-	-	Gold-Plated	-	-
AT60-220-1231-1820	Pin	Machined	Size 12	25A	18-20AWG	-	-	Gold-Plated	-	-
AT62-203-12141-10	Socket	Machined	Size 12	25A	10-12AWG	-	-	Nickel-Plated	-	-
AT62-203-12141	Socket	Machined	Size 12	25A	12-14AWG	-	-	Nickel-Plated	-	-
AT62-203-12NKIT	Socket	Machined	Size 12	25A	12-14AWG	-	-	Nickel-Plated	-	-
AT62-210-1231	Socket	Machined	Size 12	25A	12-14AWG	-	-	Gold-Plated	-	-
AT62-210-1231-1618	Socket	Machined	Size 12	25A	16-18AWG	-	-	Gold-Plated	-	-
AT62-210-1231-1820	Socket	Machined	Size 12	25A	18-20AWG	-	-	Gold-Plated	-	-

Contacts - Stamped & Formed

AT60-12-0222	Pin	S&F	Size 12	25A	10-12AWG	6.0-4.0mm ²	3.56 - 5.18mm	Nickel-Plated	-	-
AT60-12-0222-LP	Pin	S&F	Size 12	25A	10-12AWG	6.0-4.0mm ²	3.56 - 5.18mm	Nickel-Plated	-	Loose Piece
AT60-12-0244	Pin	S&F	Size 12	25A	10-12AWG	6.0-4.0mm ²	3.56 - 5.18mm	Gold-Plated	-	-
AT60-12-0244-LP	Pin	S&F	Size 12	25A	10-12AWG	6.0-4.0mm ²	3.56 - 5.18mm	Gold-Plated	-	Loose Piece
AT60-12-0144	Pin	S&F	Size 12	25A	12-14AWG	4.0-2.0mm ²	2.87 - 4.47mm	Gold-Plated	-	-
AT60-12-0144-LP	Pin	S&F	Size 12	25A	12-14AWG	4.0-2.0mm ²	2.87 - 4.47mm	Gold-Plated	-	Loose Piece
AT60-12-0166	Pin	S&F	Size 12	25A	12-14AWG	4.0-2.0mm ²	2.87 - 4.47mm	Nickel-Plated	-	-
AT60-12-0166-LP	Pin	S&F	Size 12	25A	12-14AWG	4.0-2.0mm ²	2.87 - 4.47mm	Nickel-Plated	-	Loose Piece
AT62-12-0222	Socket	S&F	Size 12	25A	10-12AWG	6.0-4.0mm ²	3.56 - 5.18mm	Nickel-Plated	-	-
AT62-12-0222-LP	Socket	S&F	Size 12	25A	10-12AWG	6.0-4.0mm ²	3.56 - 5.18mm	Nickel-Plated	-	Loose Piece
AT62-12-0244	Socket	S&F	Size 12	25A	10-12AWG	6.0-4.0mm ²	3.56 - 5.18mm	Gold-Plated	-	-
AT62-12-0244-LP	Socket	S&F	Size 12	25A	10-12AWG	6.0-4.0mm ²	3.56 - 5.18mm	Gold-Plated	-	Loose Piece
AT62-12-0144	Socket	S&F	Size 12	25A	12-14AWG	4.0-2.0mm ²	2.87 - 4.47mm	Gold-Plated	-	-
AT62-12-0144-LP	Socket	S&F	Size 12	25A	12-14AWG	4.0-2.0mm ²	2.87 - 4.47mm	Gold-Plated	-	Loose Piece
AT62-12-0166	Socket	S&F	Size 12	25A	12-14AWG	4.0-2.0mm ²	2.87 - 4.47mm	Nickel-Plated	-	-
AT62-12-0166-LP	Socket	S&F	Size 12	25A	12-14AWG	4.0-2.0mm ²	2.87 - 4.47mm	Nickel-Plated	-	Loose Piece

Tooling

Part Number	Tool Name	Style	Contact Size	Wire Range (AWG)	Material	Color
MXF-3966	Contact Locator for Hand Crimp Tool M300-25A	Machined	Size 12	10AWG	-	-
AUTK-12	Hand Crimp Tool	Machined	Size 12	10-18AWG	-	-
M300-25A	Hand Crimp Tool w MXF-3966 Locator	Machined	Size 12	10-18AWG	-	-
CA-5E12	Pneumatic Crimp Tool	Machined	Size 12/16/20	12-26AWG	-	-
CA-5D12	Universal Hand Crimp Tool	Machined	Size 12/16/20	12-26AWG	-	-
AUTK-100	Universal Heavy Duty Contact Crimping Tool Kit	Machined	Size 12/16/20	12-26AWG	-	-

AHD, ARB, ATP, ATHD, DuraMate™ and PanelMate™ Series

Size 12 Contact & Tooling Options, cont.

Tooling, cont.

Part Number	Tool Name	Style	Contact Size	Wire Range (AWG)	Material	Color
MFX-3973-G or K	Crimp Die Press Applicator	S&F	Size 12	12AWG	-	-
MFX-3985-G or K	Crimp Die Press Applicator	S&F	Size 12	10-12AWG	-	-
ATT-12-00	Hand Crimp Tool	S&F	Size 12	12-14AWG	-	-
ATT-12-01	Hand Crimp Tool	S&F	Size 12	10AWG	-	-
ATRT-100	Contact and Wedgelock Extraction Tool	Universal	Universal	-	Steel	Silver
AT11-337-1205	Contact Extraction Tool	Universal	Size 12	-	Plastic	Orange
A114017	Seal Plug	Universal	Size 12/16	-	Thermoplastic	White